

AVL TestStation Components

Content

Page 2	Trolleys
Page 6	TestStations
Page 7	Rectangular Tables
Page 8	Monitor Stands
Page 11	Consoles
Page 12	Examples of how to assemble AVL TestStation components



Trolleys

There are three different types of trolleys available to be connected to a TestStation: Trolley with open Front, Trolley with aluminium Door and Trolley with transparent Door.

In addition there is an Office Trolley 19" with open Front available to be placed freely within the operating room.

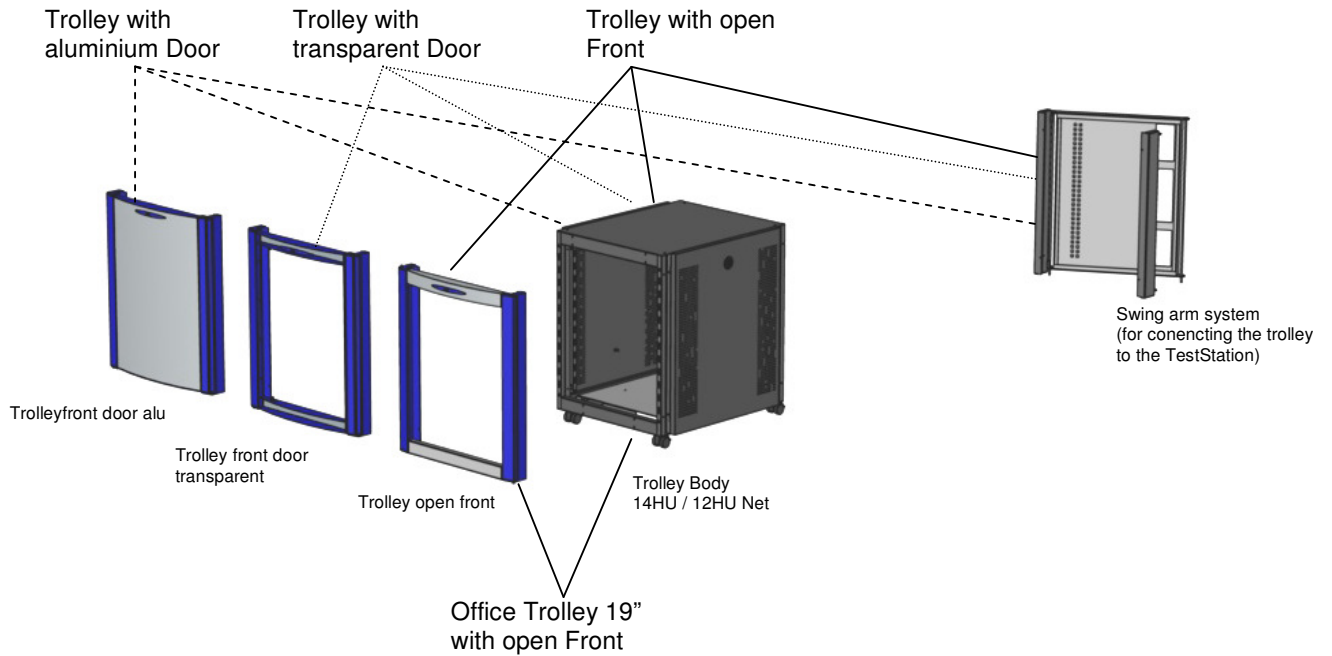

Dimensions:

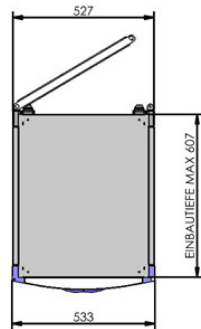
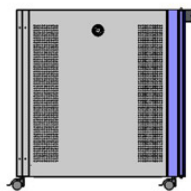
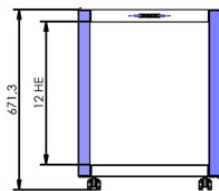

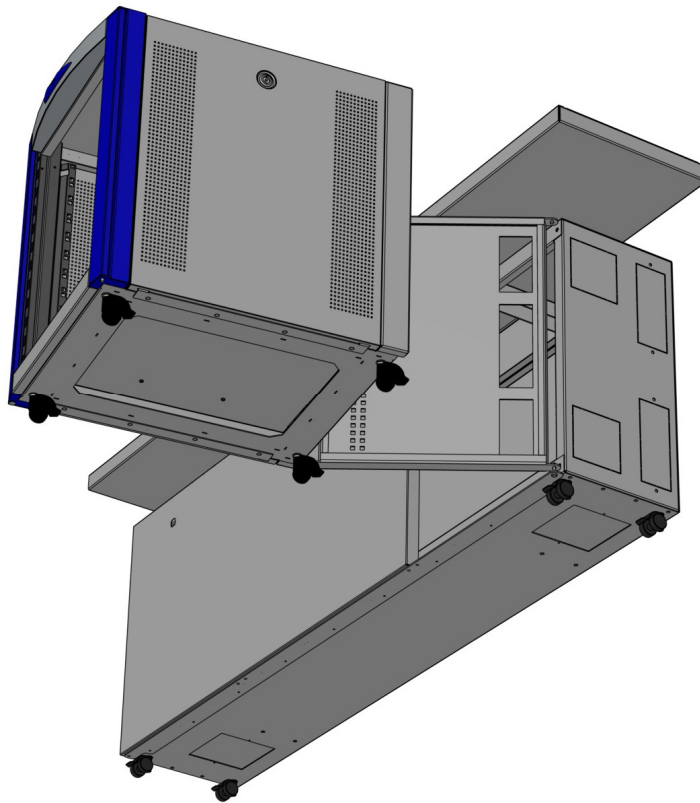
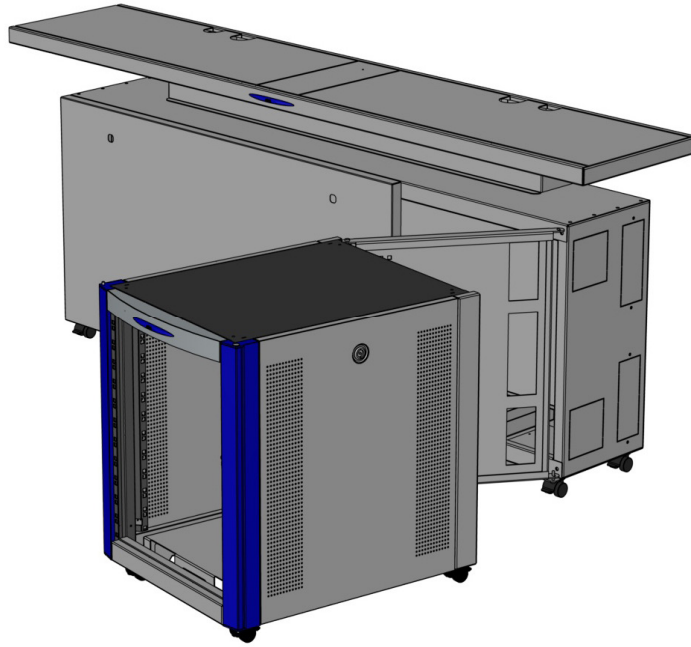

Trolley **How to mount the swing arm**

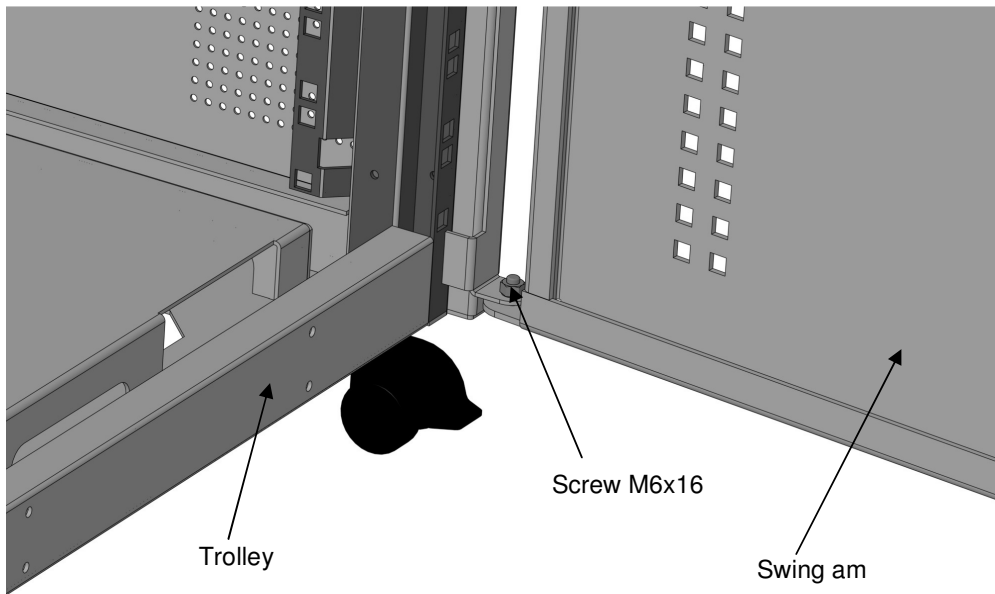
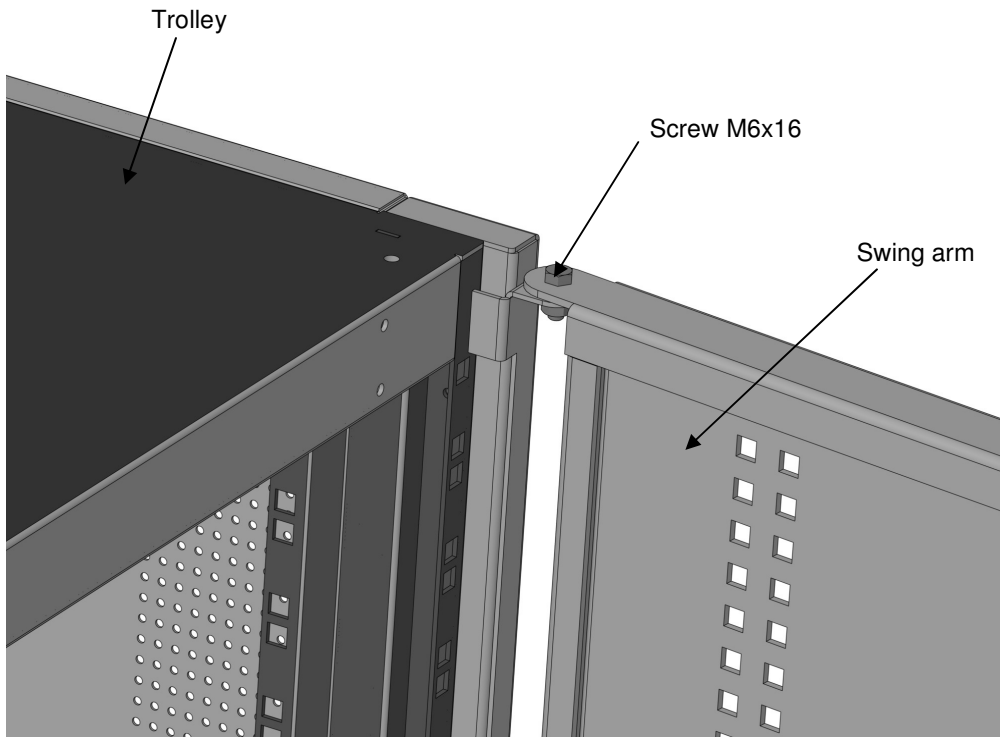

Trolley

How to mount the swing arm to the TestStation

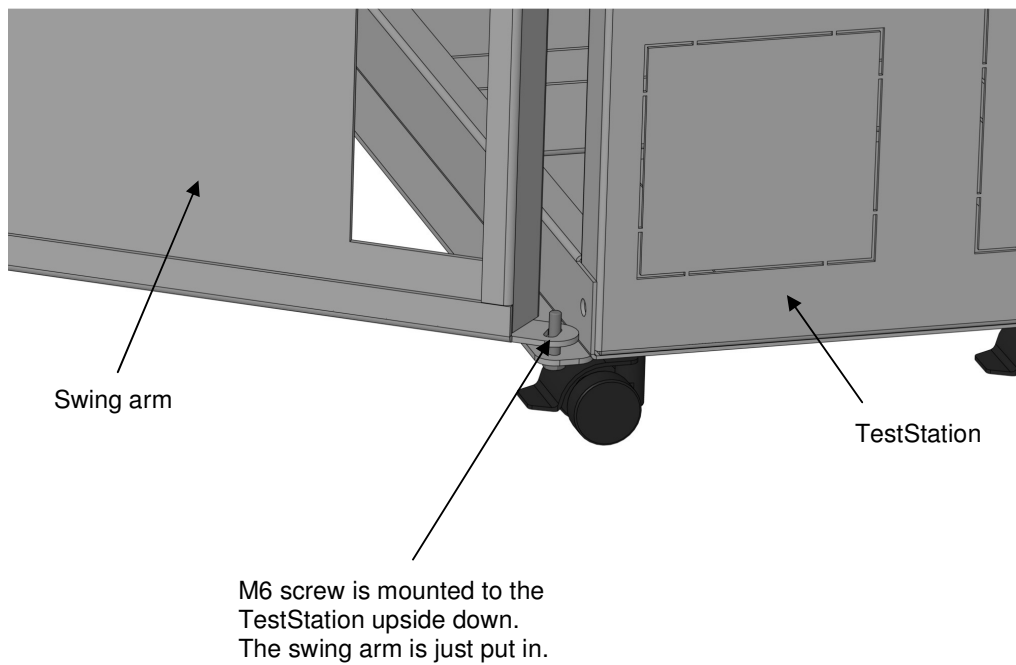
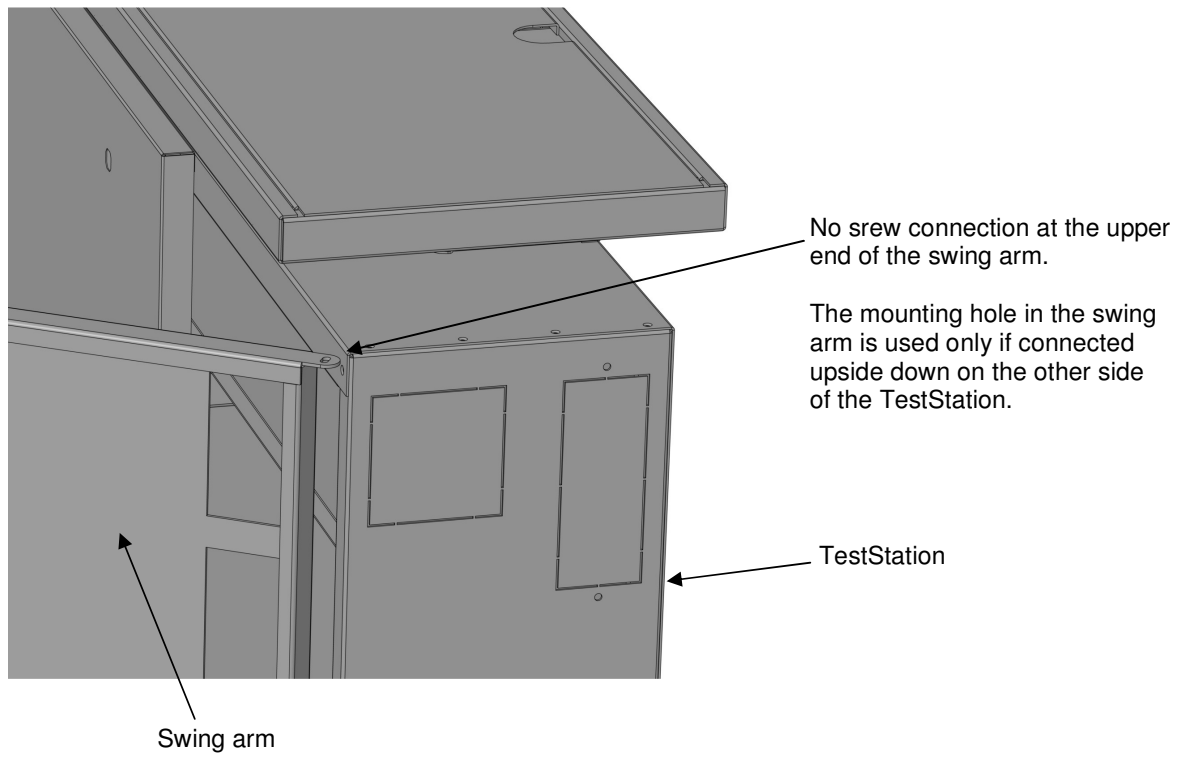

TestStations

There are three different sizes available: TestStation 160, TestStation 200, TestStation 250

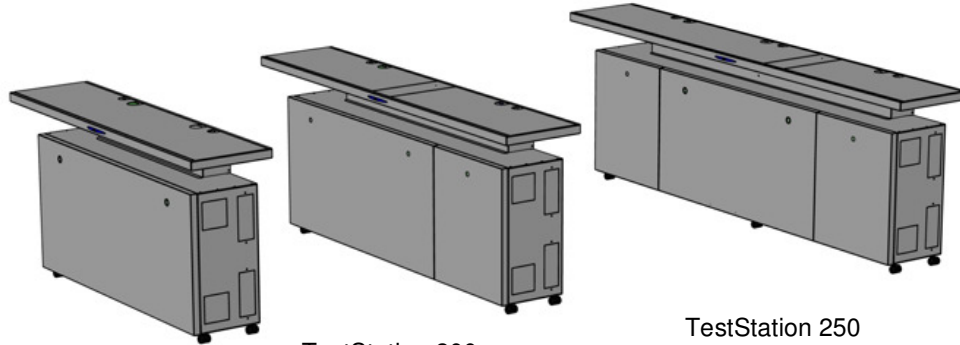

Note: Each TestStation is delivered together with a table on four wheels (see next page).

Dimensions:

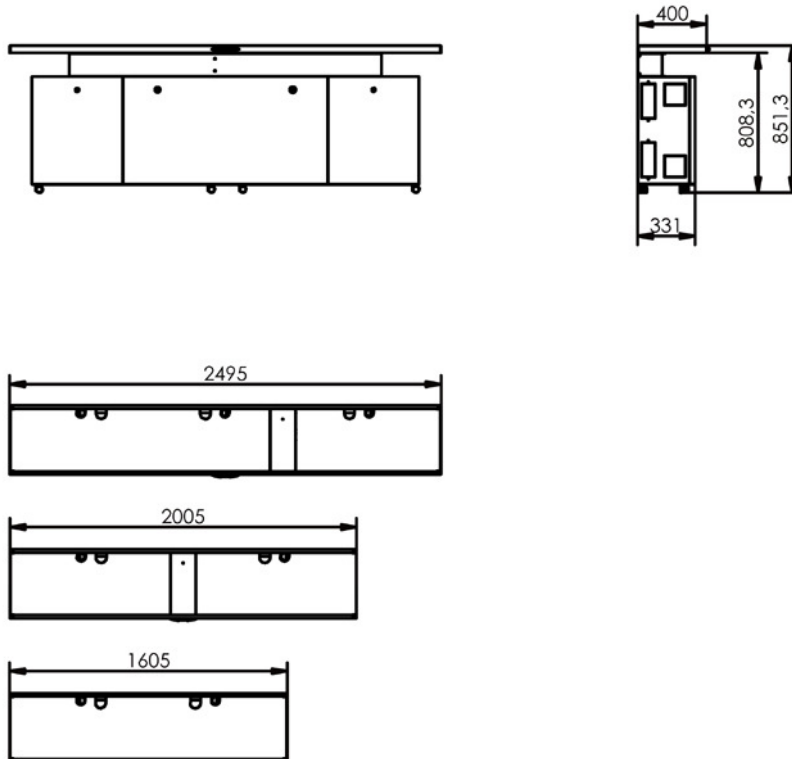

Rectangular Tables

Tables suitable for TestStation 250:

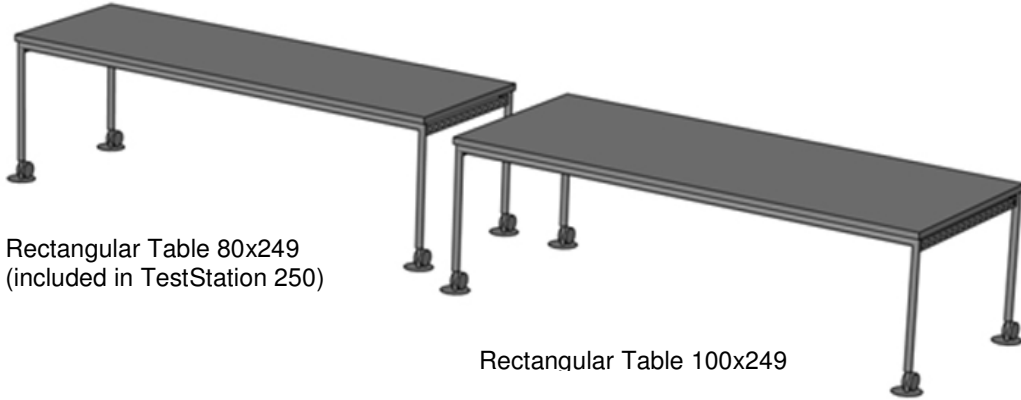

Rectangular Table 80x249
(included in TestStation 250)

Rectangular Table 100x249

Tables suitable for TestStation 200:

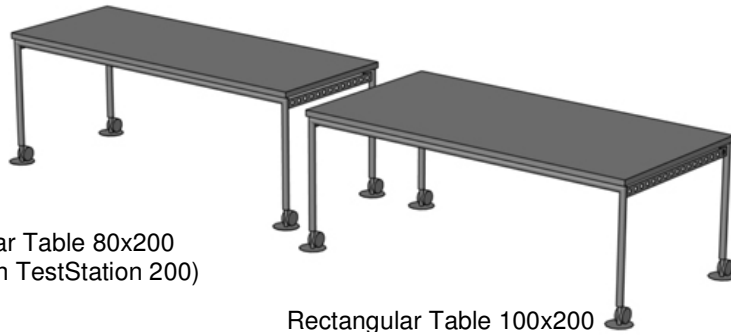

Rectangular Table 80x200
(included in TestStation 200)

Rectangular Table 100x200

Table suitable for TestStation 160



Rectangular Table 80x160
(included in TestStation 160)

Monitor Stands

Monitor Stand 4 TFT

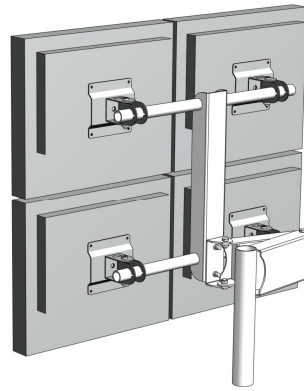

Monitor Stand 2 TFT horizontal

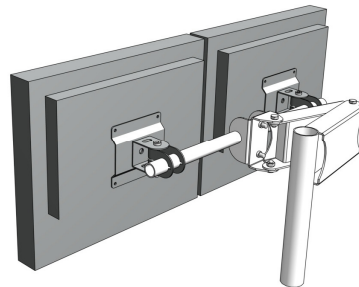
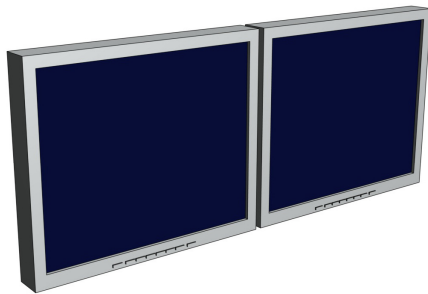

Monitor Stand 2 TFT vertical

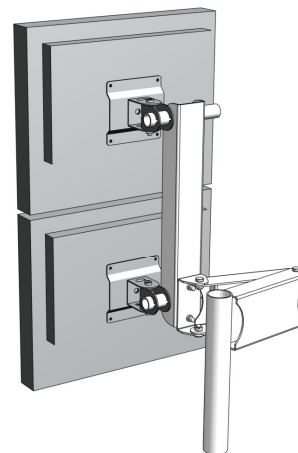
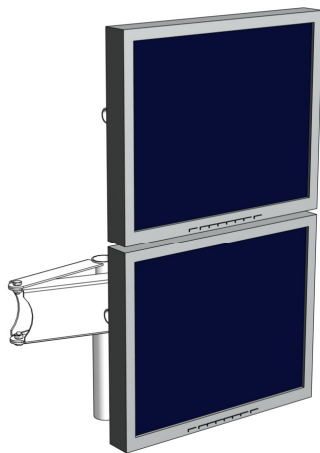

Monitor Arms

The adjustable monitor arm can be mounted at the right or left side of the TestStation. Separate article codes are available for each side – see the Configuration Guide.

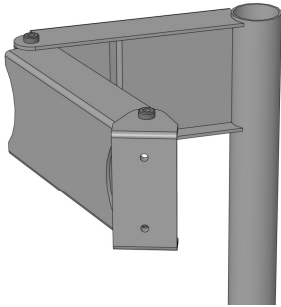

Monitor Arm adj. left
To be mounted on the left side of the TestStation.

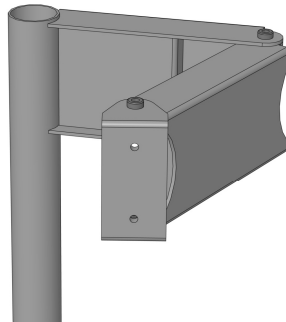

Monitor Arm adj. right
To be mounted on the right side of the TestStation.

Monitor Stands mounted to a TestStation Overview

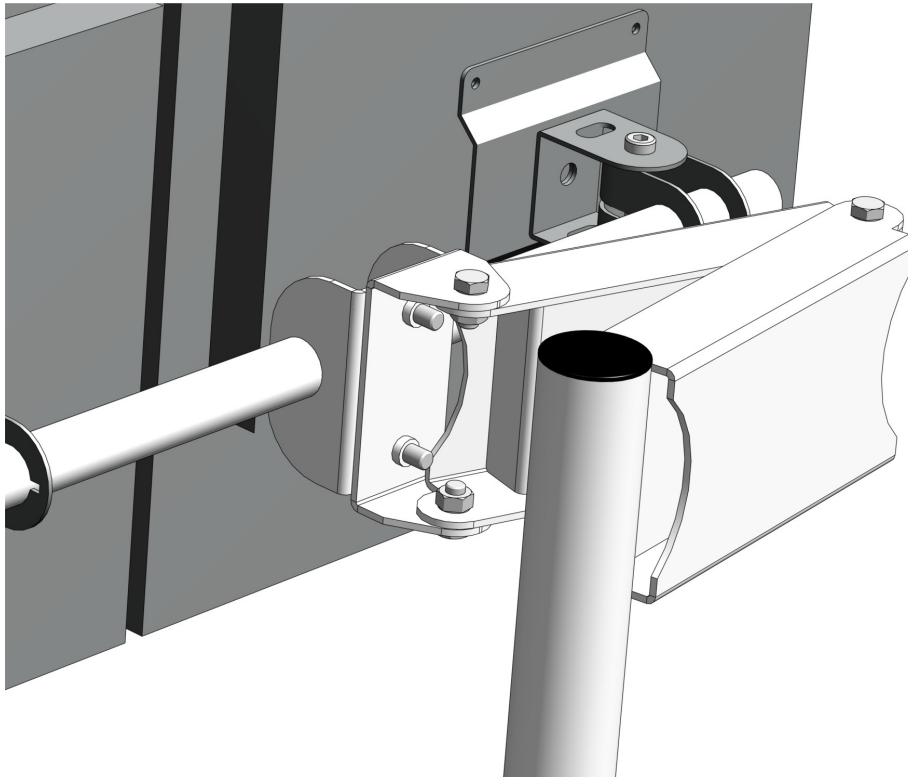

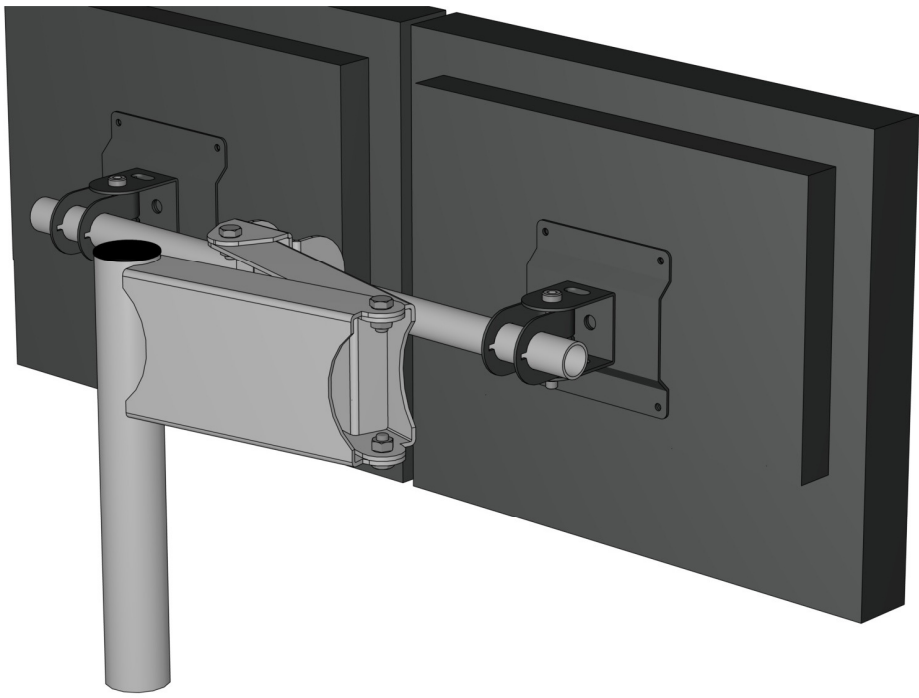

Consoles

Two different types of consoles are available.

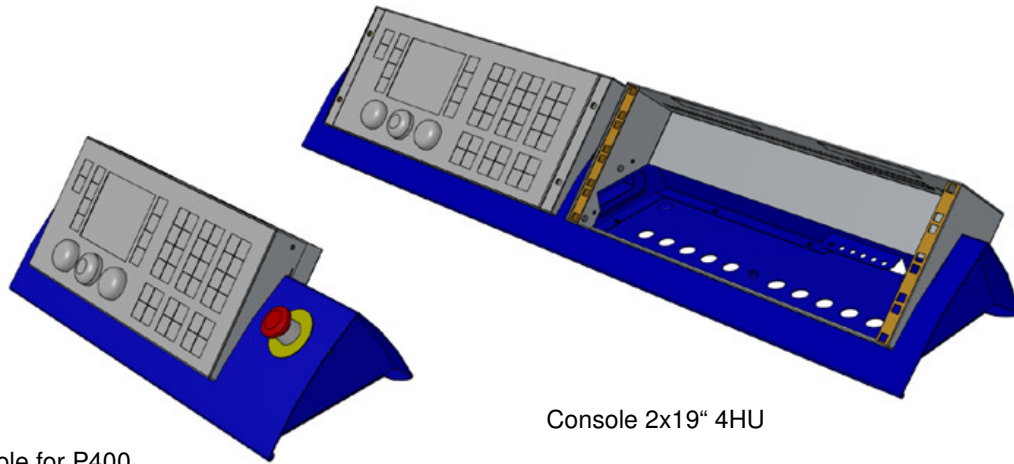

Console for P400

Console 2x19" 4HU

Dimensions:

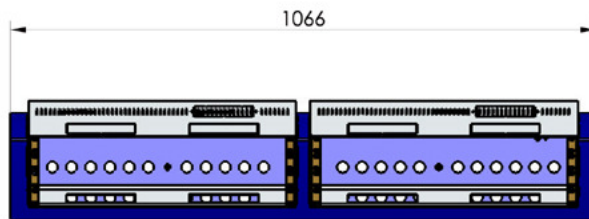
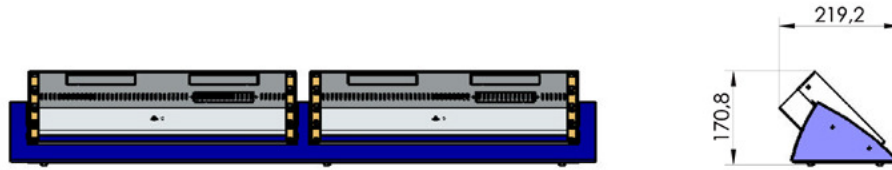

Console 2x19" 4HU

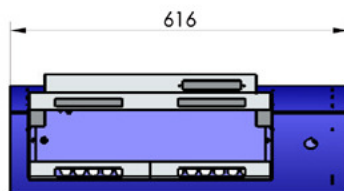

Console for P400

Examples of how to assemble AVL TestStation components

Example 1:

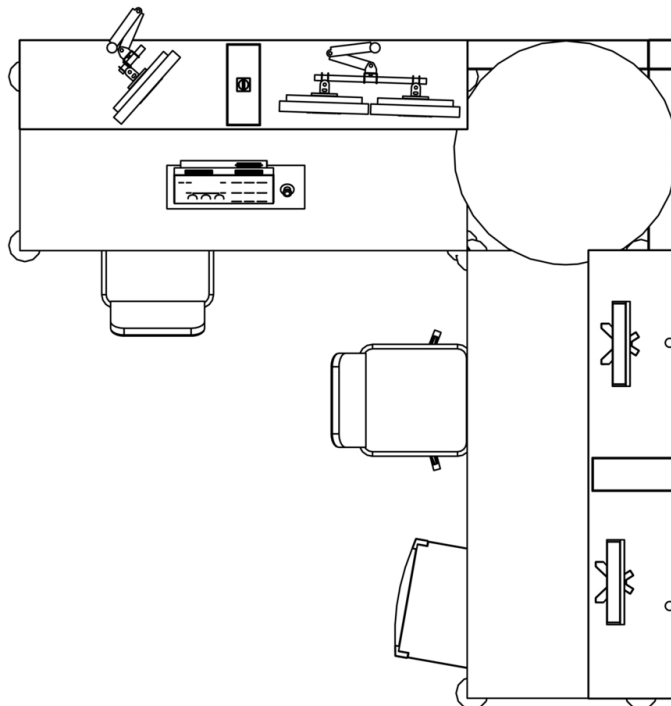

Example 2:

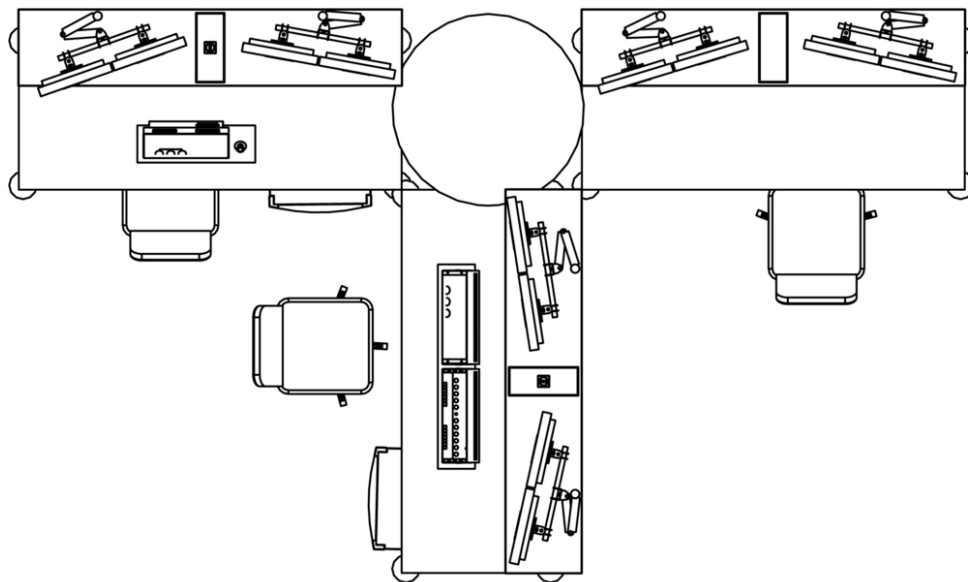

Example 3:

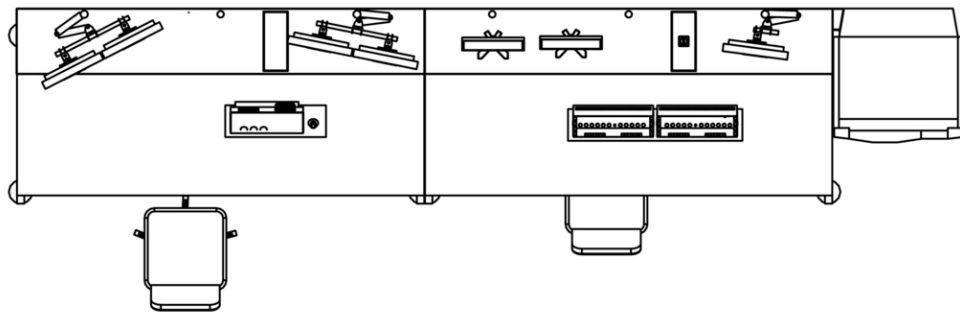
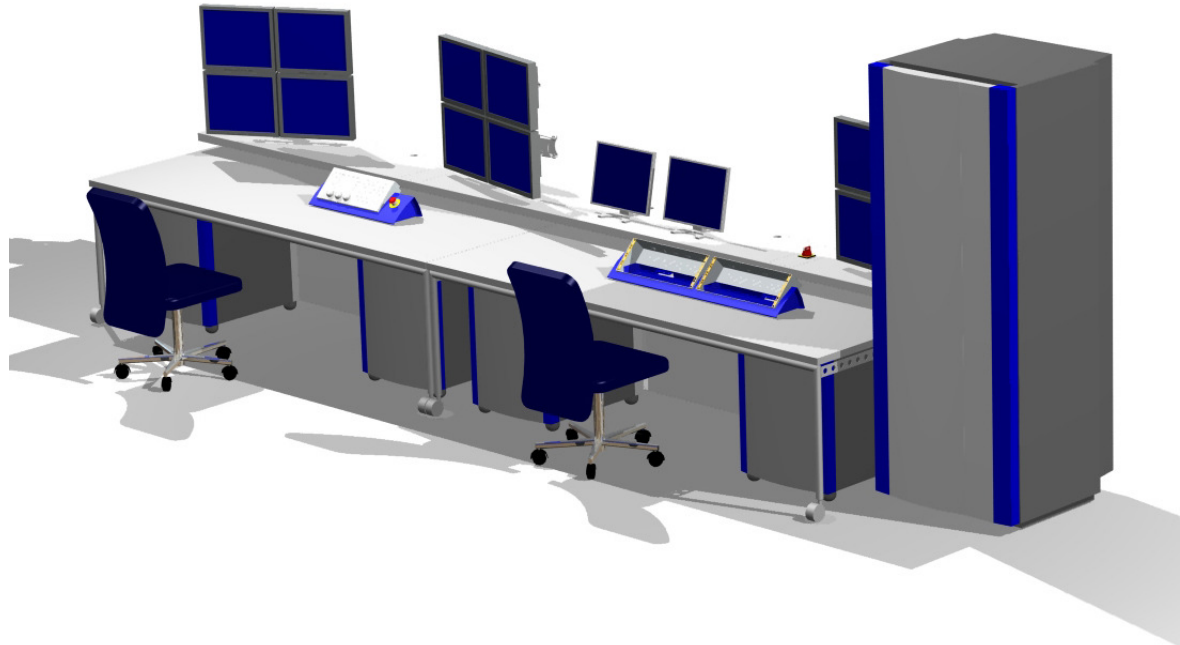

Example 4:

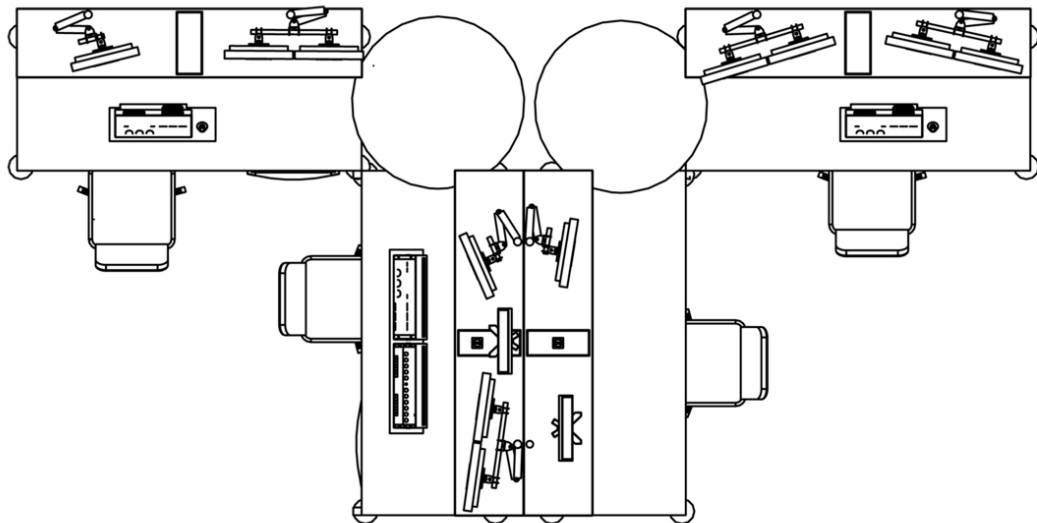

Example 5:



The tables are freely movable on their wheels.

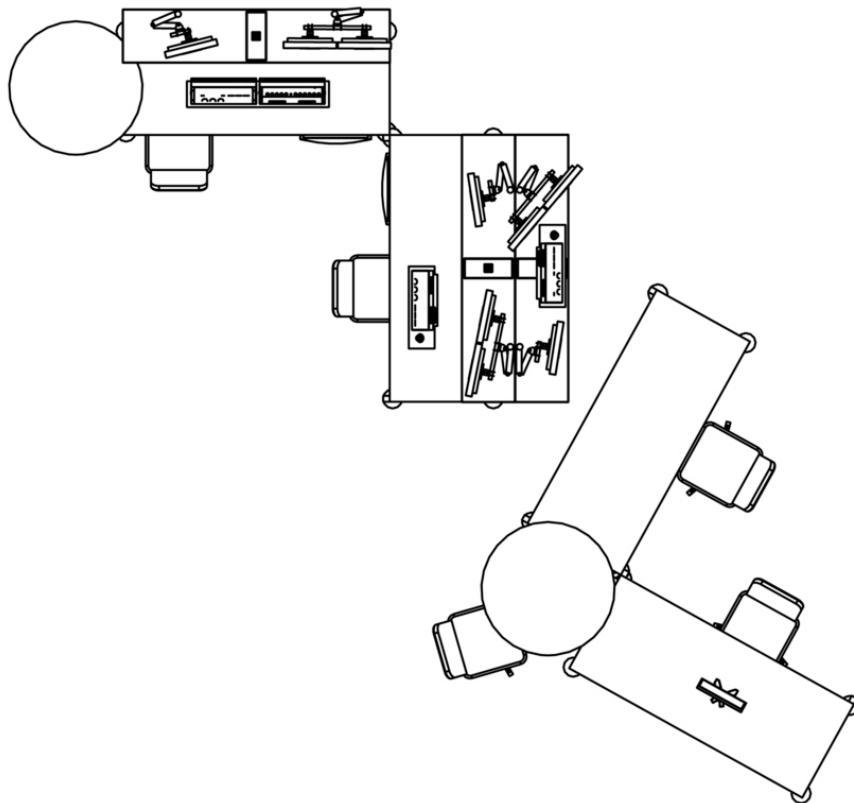

Example 6:

